

THIS DWG. IS SOLE PROPERTY OF NEOMETRIX ENGINEERING PVT. LTD.
UNAUTHORISED USE OF THIS DWG. OR MAKING PRODUCT AS PER THIS DWG.
WITHOUT OUR PERMISSION OR ANY OTHER MISUSE IS NOT PERMITTED.

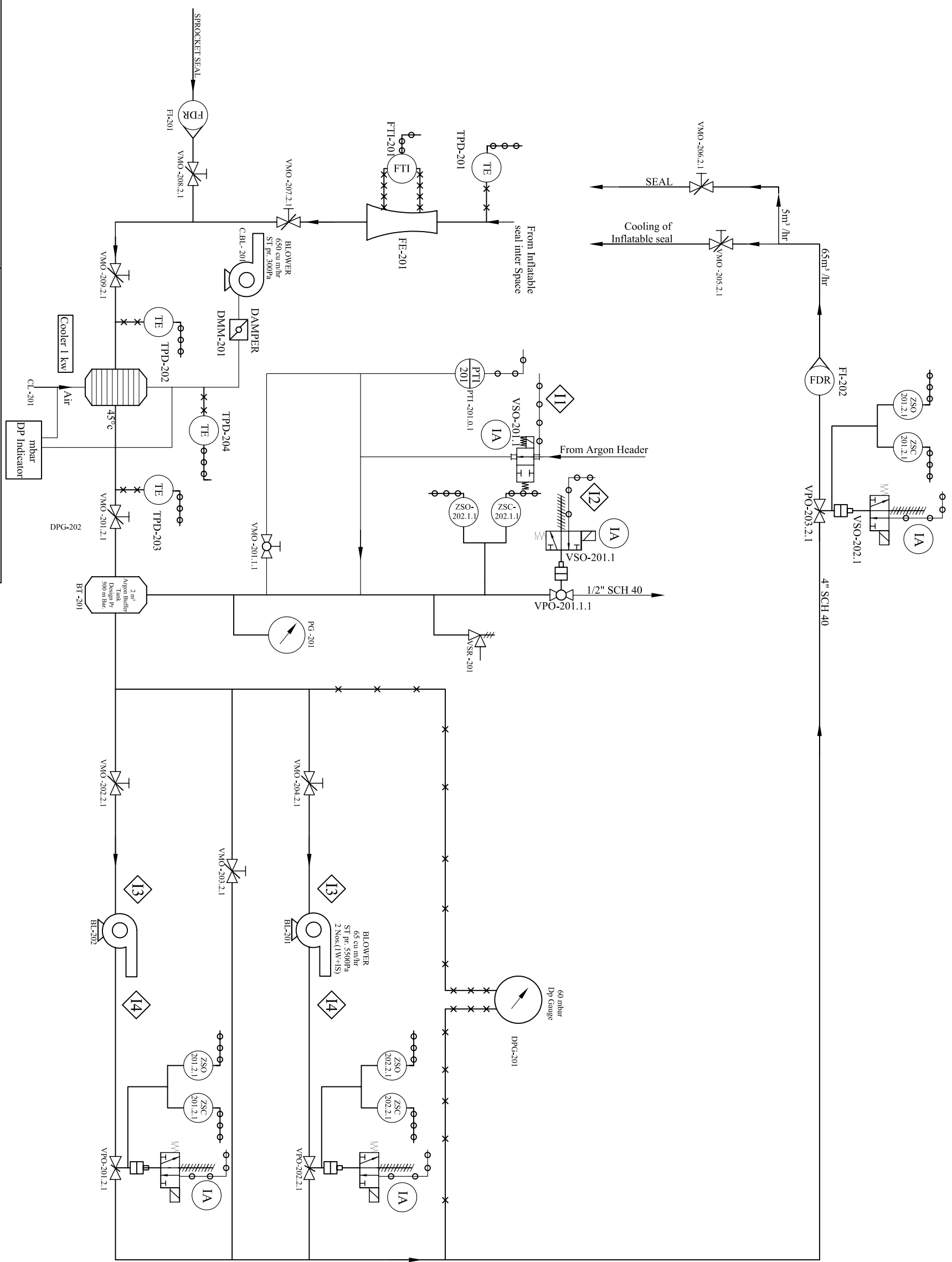

SYMBOLS

SERVICE

GAS LINE

ELECTRICAL IMPULSE

INSTRUMENT CAPILLARY TUBING

INSTRUMENT AIR (IA)

- INTERLOCK DETAILS**
- ◇11 ARGON SUPPLY ON/OFF
 - ◇12 PRESSURE RELIEF
 - ◇13 INTERLOCK WITH COOLER
 - ◇14 BLOWER MUTUALLY INTERLOCK

Colour	Pipe size
	1/2"
	4"
	DUCTING

Item	DESCRIPTION	QTY
1	VPO - Pneumatic Operated Valve - 1/2"	01
2	VPO - Pneumatic Operated Valve - 4"	03
3	VMO - Manually Operated Valve - 4"	09
4	VSR - Safety Valve	01
5	DMM - Manually Operated Damper	01
6	FTI - Flow Transmitter & Indicator @ 45°C	01
7	PTI - Pressure Transmitter & Indicator @ 45°C	02
8	FDR - Rota Meter @ 45°	04
9	TPD - Thermo Couple	01
10	P.G. - Pressure Gauge	01
11	DPG - Differential Pressure Gauge	01
12	CL - Cooler	01
13	C.B.L. - Cooler Blower	01
14	BLW - Blower	02
15	VSO - Solenoid Valve - 1/4"	03
16	VSO - Solenoid Valve - 1/2"	01
17	BT - Buffer Tank	01
18	VMO - Manually Operated Valve - 1/2"	

NEOMETRIX ENGINEERING PRIVATE LIMITED
I-148, SECTOR-66, NOIDA-201301 (UP)
Tel: Phone No. - 0120-4590800
Fax No. - 0120-4590888
Email: sales@neometrix.in
www.neometrixindia.com

MAIN TITLE	ARGON COOLING SYSTEM	DATE	
SUB - TITLE	REL DIAGRAM	DESIGNED BY	LS
CODE	ARG60	CHECKED BY	LS
CUSTOMER	IGCAR	NOTES	
END USER	IGCAR		
APPLICATION	LCTR		
PRODUCTION	DESIGNED BY: SR	SIZE	A4
	CHECKED BY: SR	SCALE	N.T.S
	APPROVED BY: SR	SHEET NO.	01
		TOTAL SHEETS	05