

THIS DWG. IS SOLE PROPERTY OF NEOMETRIX ENGINEERING PVT. LTD.
 UNAUTHORISED USE OF THIS DWG. OR MAKING PRODUCT AS PER THIS DWG.
 WITHOUT OUR PERMISSION OR ANY OTHER MISUSE IS NOT PERMITTED.

MICRO PROCESSOR CONTROLLED DV TEST BENCH

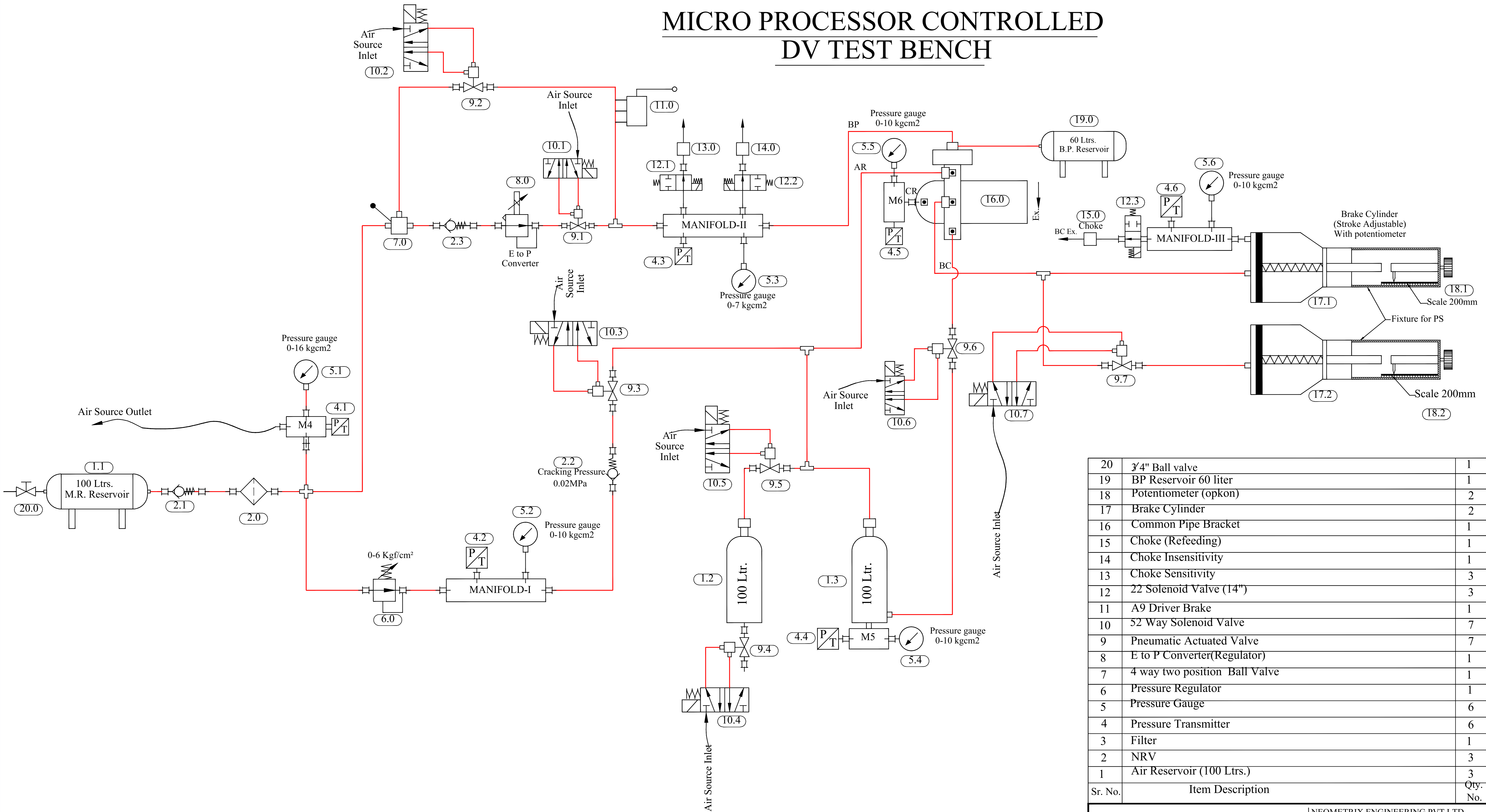

20	3/4" Ball valve	1
19	BP Reservoir 60 liter	1
18	Potentiometer (opkon)	2
17	Brake Cylinder	2
16	Common Pipe Bracket	1
15	Choke (Refeeding)	1
14	Choke Insensitivity	1
13	Choke Sensitivity	3
12	22 Solenoid Valve (14")	3
11	A9 Driver Brake	1
10	52 Way Solenoid Valve	7
9	Pneumatic Actuated Valve	7
8	E to P Converter(Regulator)	1
7	4 way two position Ball Valve	1
6	Pressure Regulator	1
5	Pressure Gauge	6
4	Pressure Transmitter	6
3	Filter	1
2	NRV	3
1	Air Reservoir (100 Ltrs.)	3
Sr. No.	Item Description	Qty. No.

NEOMETRIX
www.neometrixgroup.com

NEOMETRIX ENGINEERING PVT.LTD.
 E-148, Sector-63, Noida, UP-201301
 Tel. No.- 0120-4500800
 Fax No.- 0120-4500888
 E Mail: contact@neometrix.in

MAIN TITLE		DV TEST RIG		O.A No.			
SUB - TITLE		PNEUMATIC CIRCUIT DIAGRAM		CROSS REF. DOC.			
CODE		A1721		CUSTOMER DWG. REF. No.			
CUSTOMER				NOTES:			
END USER							
APPLICATION				Rev.		00	
PROJECTION	DRAWN BY & DATE	SK	10/04/18	Sheet	SCALE	SHEET	NEO. DWG. NO.
	CHECKED BY & DATE	SK	10/04/18	A4	NTS	01 OF 01	T-PED-PDWG-A1721
	APPROVED BY & DATE	SPS	10/04/18				