

THIS DWG. IS SOLE PROPERTY OF NEOMETRIX ENGINEERING PVT. LTD.
UNAUTHORISED USE OF THIS DWG. OR MAKING PRODUCT AS PER THIS DWG.
WITHOUT OUR PERMISSION OR ANY OTHER MISUSE IS NOT PERMITTED.

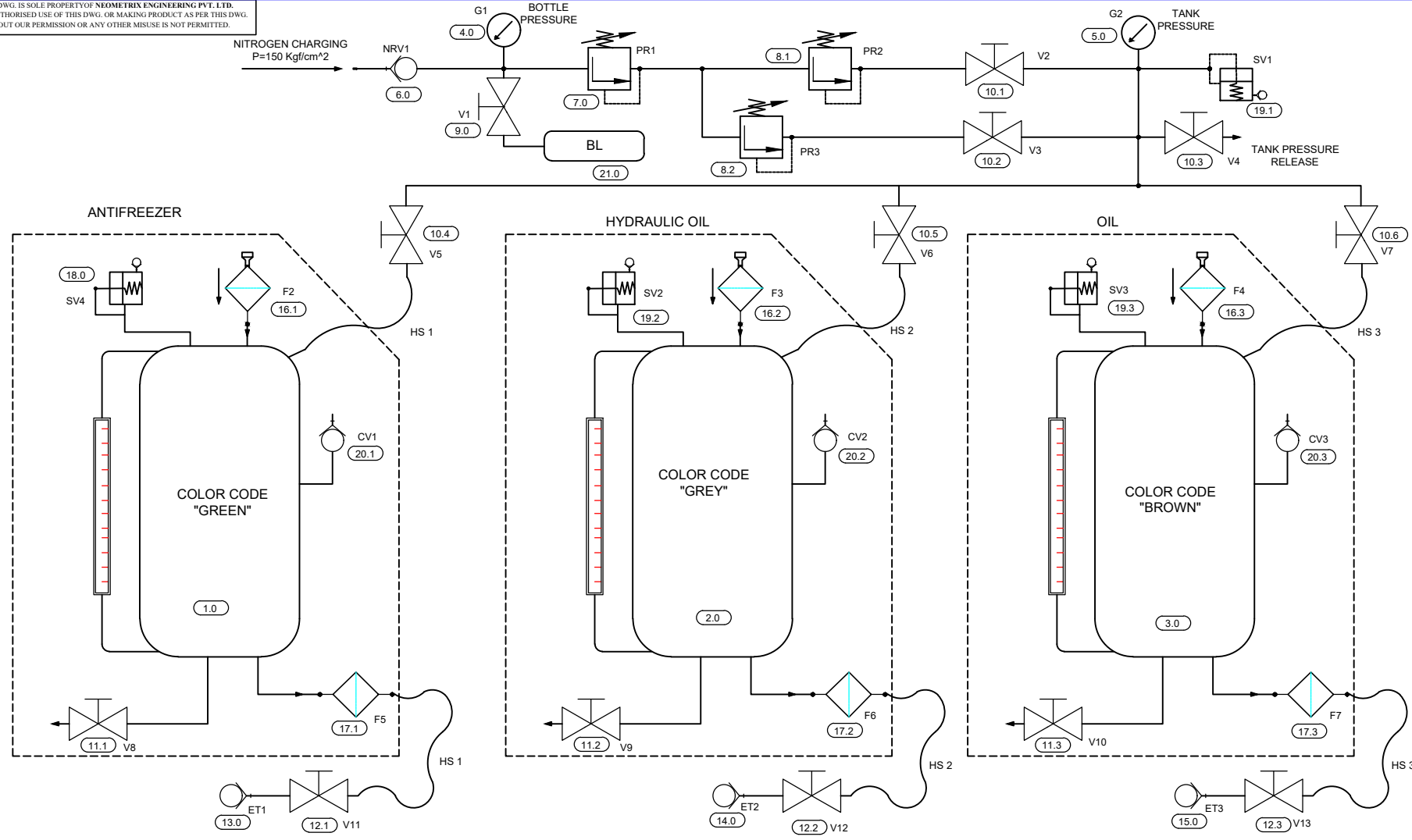

HS1-HS3	HOSE ASSY	3
ET3	OIL CHARGING VALVE	1
ET2	HYD OIL CHARGING VALVE	1
ET1	ANTIFREEZER CHARGING VALVE	1
F7	HYDRAULIC FILTER	1
F6	HYDRAULIC FILTER	1
F5	HYDRAULIC FILTER	1
PR2-PR3	PRESSURE REDUCER WITH FILTER	2
PR1	PRESSURE REDUCER	1
G2	PR GUAGE-Ø100	1
G1	PR GUAGE-Ø100	1
SV4	SAFETY VALVE	1
SV1-SV3	SAFETY VALVE	3
CV1-CV3	CHARGING VALVE	3
V8-V10	DRAIN VALVE	3
V11-V13	NEEDLE VALVE	3
V2-V7	NEEDLE VALVE	6
V1	NEEDLE VALVE	1
NRV1	NON RETURN VALVE	1
BL	AIR BOTTLE-40LTR	1
F2-F4	FILLING NECK WITH FILTER	3
T1-T3	TANK ASSY	3
POSITION	DESCRIPTION	QTY

HYDRAULIC CIRCUIT DIAGRAM

TANK NO.	WORKING FLUID	
1	ANTIFREEZER	
2	HYDRAULIC OIL	
3		

NOTE:
This is Tentative Drawing for Tender purpose only, Subject To Change.

NEOMETRIX ENGINEERING PVT. LTD.
E-148, Sector-63, Noida, UP-201301
Tel. No. :- 0120-4500800
Fax No. :- 0120-4500888
Email :- contact@neometrixgroup.com

MAIN TITLE	AMZ OIL CHARGING TROLLY FOR SU-30MKI	Q.A. No.	01
SUB - TITLE	HYDRAULIC CIRCUIT DIAGRAM	Cross Ref. Doc. No.	
CODE	A4384	Customer Dwg./Ref. No.	
CUSTOMER	IAF	Note:	
END USER	IAF		
PO. No.	..		

PROJECTION	DRAWN BY & DATE	ALOK 11/08/2023	Size	Scale	Sheet	NEO. DWG. No.	REV
	CHECKED BY & DATE	ABHAY 11/08/2023	A3	NTS	01/01	T04P-A4384-H003-HYDRAULIC CIRCUIT DIAGRAM	01
	APPROVED BY & DATE	S.P.S. 11/08/2023					