

THIS DWG. IS SOLE PROPERTY OF NEOMETRIX ENGINEERING PVT. LTD.  
 UNAUTHORISED USE OF THIS DWG. OR MAKING PRODUCT AS PER THIS DWG.  
 WITHOUT OUR PERMISSION OR ANY OTHER MISUSE IS NOT PERMITTED.

Colour	Tube Size
	1/4"
	3/4"

## MICRO PROCESSOR CONTROLLED DV TEST BENCH

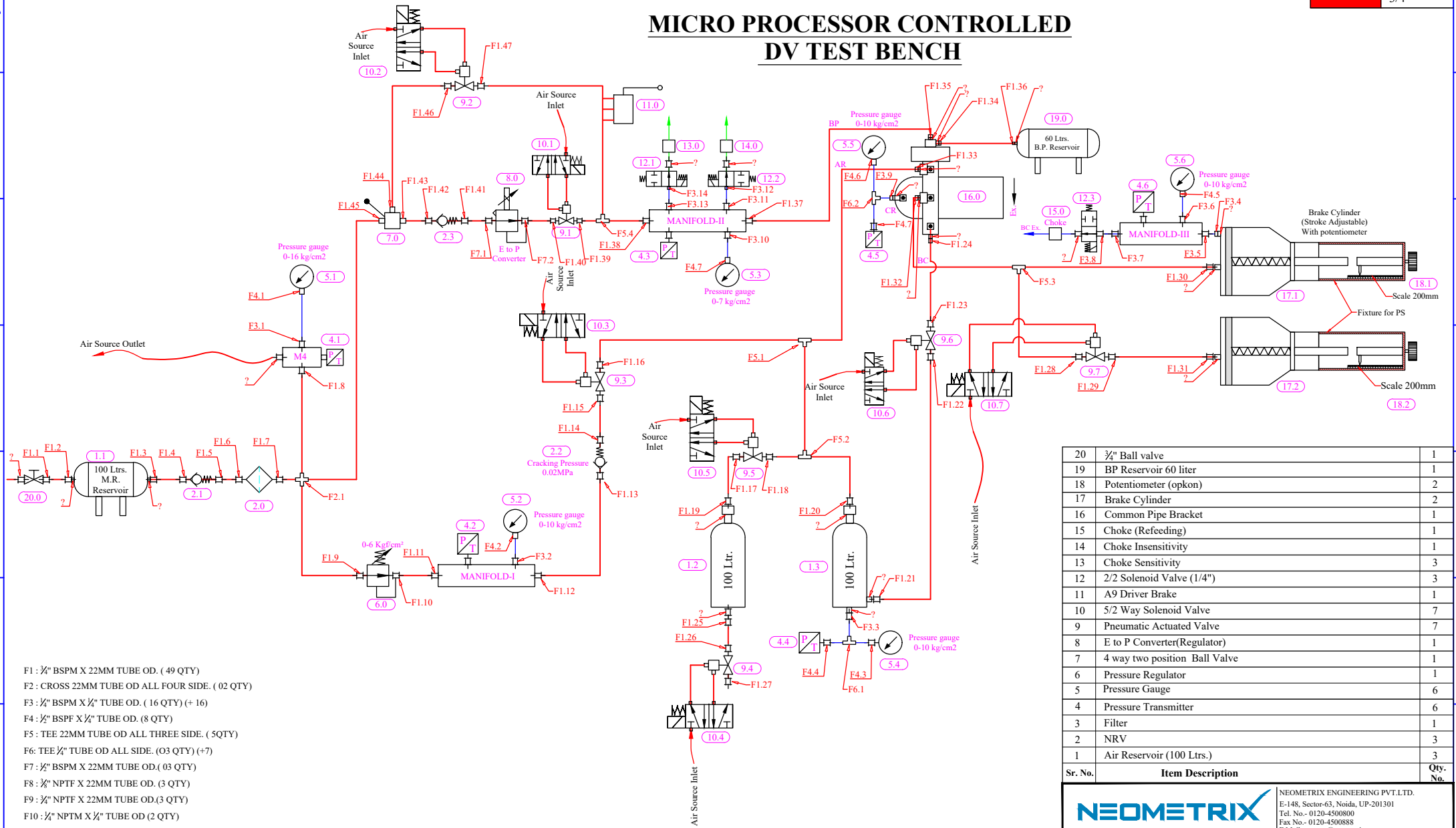

- F1 : 3/4" BSPM X 22MM TUBE OD. ( 49 QTY)
- F2 : CROSS 22MM TUBE OD ALL FOUR SIDE. ( 02 QTY)
- F3 : 1/2" BSPM X 1/2" TUBE OD. ( 16 QTY) (+ 16)
- F4 : 1/2" BSPF X 1/2" TUBE OD. ( 8 QTY)
- F5 : TEE 22MM TUBE OD ALL THREE SIDE. ( 5QTY)
- F6: TEE 1/2" TUBE OD ALL SIDE. (03 QTY) (+7)
- F7 : 1/2" BSPM X 22MM TUBE OD. (03 QTY)
- F8 : 3/8" NPTF X 22MM TUBE OD. (3 QTY)
- F9 : 3/8" NPTF X 22MM TUBE OD.(3 QTY)
- F10 : 1/2" NPTM X 1/2" TUBE OD (2 QTY)

20	3/4" Ball valve	1
19	BP Reservoir 60 liter	1
18	Potentiometer (opkon)	2
17	Brake Cylinder	2
16	Common Pipe Bracket	1
15	Choke (Refeeding)	1
14	Choke Insensitivity	1
13	Choke Sensitivity	3
12	2/2 Solenoid Valve (1/4")	3
11	A9 Driver Brake	1
10	5/2 Way Solenoid Valve	7
9	Pneumatic Actuated Valve	7
8	E to P Converter(Regulator)	1
7	4 way two position Ball Valve	1
6	Pressure Regulator	1
5	Pressure Gauge	6
4	Pressure Transmitter	6
3	Filter	1
2	NRV	3
1	Air Reservoir (100 Ltrs.)	3
Sr. No.	Item Description	Qty. No.

Note:-  
This is tentative drawing, Subject to change.

**NEOMETRIX** NEOMETRIX ENGINEERING PVT.LTD.  
E-148, Sector-63, Noida, UP-201301  
Tel. No.- 0120-4500800  
Fax No.- 0120-4500888  
E Mail: contact@neometrixgroup.com

MAIN TITLE	DV TEST RIG	O.A No.	
SUB - TITLE	PNEUMATIC CIRCUIT DIAGRAM	CROSS REF. DOC.	-
CODE	A4557	CUSTOMER DWG. / REF. No.	
CUSTOMER	---	NOTES:	
END USER	---	Rev.	00
APPLICATION	---	No. OF	
PROJECTION	DRAWN BY & DATE	Z.A.	04/03/23
CHECKED BY & DATE	SK	04/03/23	
APPROVED BY & DATE	SPS	04/03/23	

SCALE: NTS      SHEET: 01 OF 01      NEO. DWG. NO. T-DAP-PDWG-A4557